









Instrucciones / Instructions / Anweisungen / Instructions

UNIKGLASS+ 100 KSC

KLEIN®

		PAG.
1	TIPOLOGÍAS DE INSTALACIÓN <i>INSTALLATION TYPES</i>	3
2	INFORMACIÓN DE SEGURIDAD <i>SAFETY INFORMATION</i>	4
3	HERRAMIENTAS NECESARIAS <i>REQUIRED TOOLS</i>	4
4	INFORMACIÓN GENERAL <i>GENERAL INFORMATION</i>	4
5	ELEMENTOS DE LA INSTALACIÓN <i>ITEMS OF INSTALLATION</i>	5
6	MONTAJE DEL PERFIL PARA INSTALACIÓN VISTA <i>UPPER TRACK MOUNTING FOR EXPOSED INSTALLATION</i>	
	6.1 A PARED <i>WALL MOUNTED</i> 	6
	6.2 A TECHO <i>CEILING MOUNTED</i> 	6
7	MONTAJE DEL PERFIL PARA INSTALACIÓN EMPOTRADA A FALSO TECHO <i>UPPER TRACK MOUNTING FOR RECESSED INSTALLATION</i>	
	FASE 1 - MONTAJE PERFIL MARCO STEP 1 - FRAME TRACK MOUNTING	
	7.1 CON DINTEL <i>WITH LINTEL</i> 	6
	7.2 SIN DINTEL <i>WITHOUT LINTEL</i> 	7
	FASE 2 - ENCUENTRO A FALSO TECHO STEP 2 - RECESSED CONNECTION	
	7.3 JUNTA ENTRE PERFIL MARCO Y PANEL <i>JOINT BETWEEN FRAME TRACK AND PLASTERBOARD</i>	8
	FASE 3 - MONTAJE PERFIL SUPERIOR STEP 3 - UPPER TRACK MOUNTING	
	7.4 CON DINTEL <i>WITH LINTEL</i> 	9
	7.5 SIN DINTEL <i>WITHOUT LINTEL</i> 	9
8	COLOCACIÓN DE MORDAZAS <i>CLAMP INSTALL</i>	10
9	COLOCACIÓN DEL GUIADOR <i>GUIDE INSTALL</i>	10
10	COLOCACIÓN DE LA PUERTA <i>DOOR MOUNTING</i>	11
11	REGULACIÓN DE LA ALTURA <i>HEIGHT ADJUSTMENT</i>	11
12	ANTIDESCABALGAMIENTO <i>ANTI-JUMP</i>	11
13	COLOCACIÓN DE LOS TOPES INFERIORES <i>BOTTOM STOPPER INSTALL</i>	12
14	COLOCACIÓN DE LOS KSC <i>KSC INSTALL</i>	13
15	COLOCACIÓN DE LA GALERÍA <i>VALANCE MOUNTING</i>	14
16	COLOCACIÓN DE LAS TAPAS LATERALES DEL PERFIL SUPERIOR <i>END CAP INSTALL</i>	14

1 TIPOLOGÍAS DE INSTALACIÓN / INSTALLATION TYPES



INSTALACIÓN VISTA A PARED
WALL MOUNTED INSTALLATION

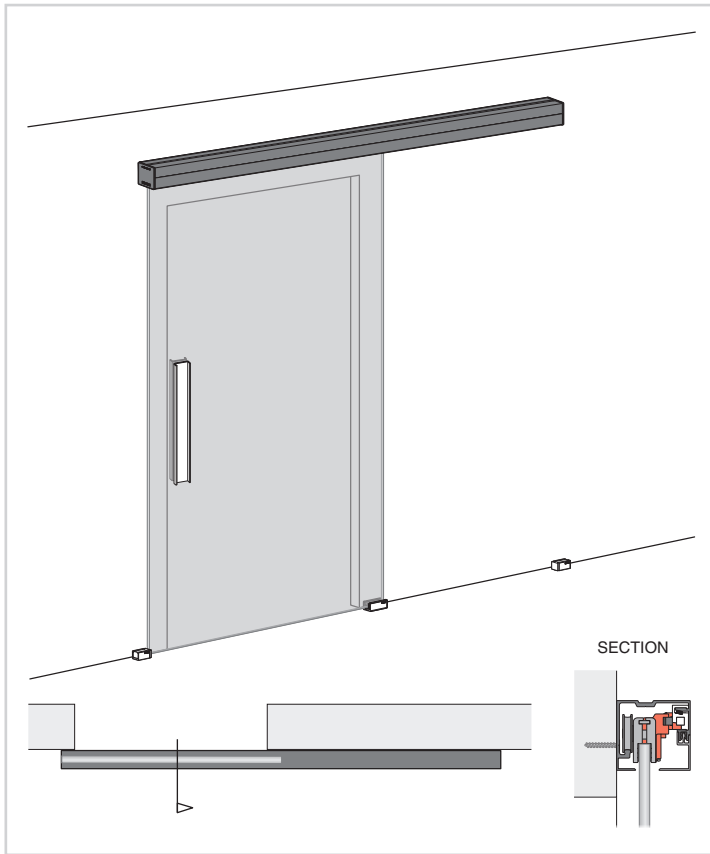

INSTALACIÓN VISTA A TECHO
CEILING MOUNTED INSTALLATION

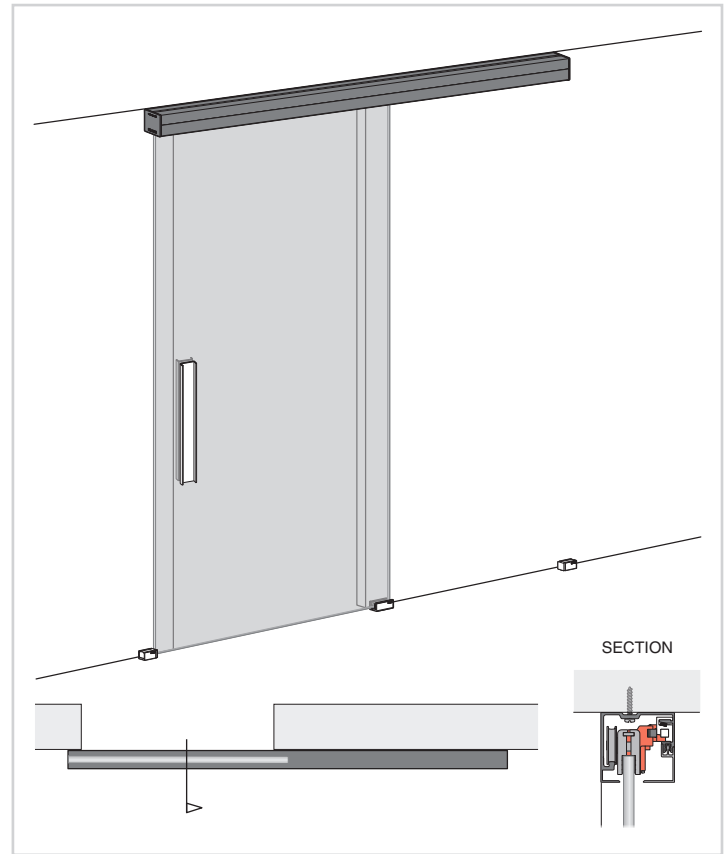

INSTALACIÓN EMPOTRADA CON DINTEL
RECESSED INSTALLATION WITH LINTEL

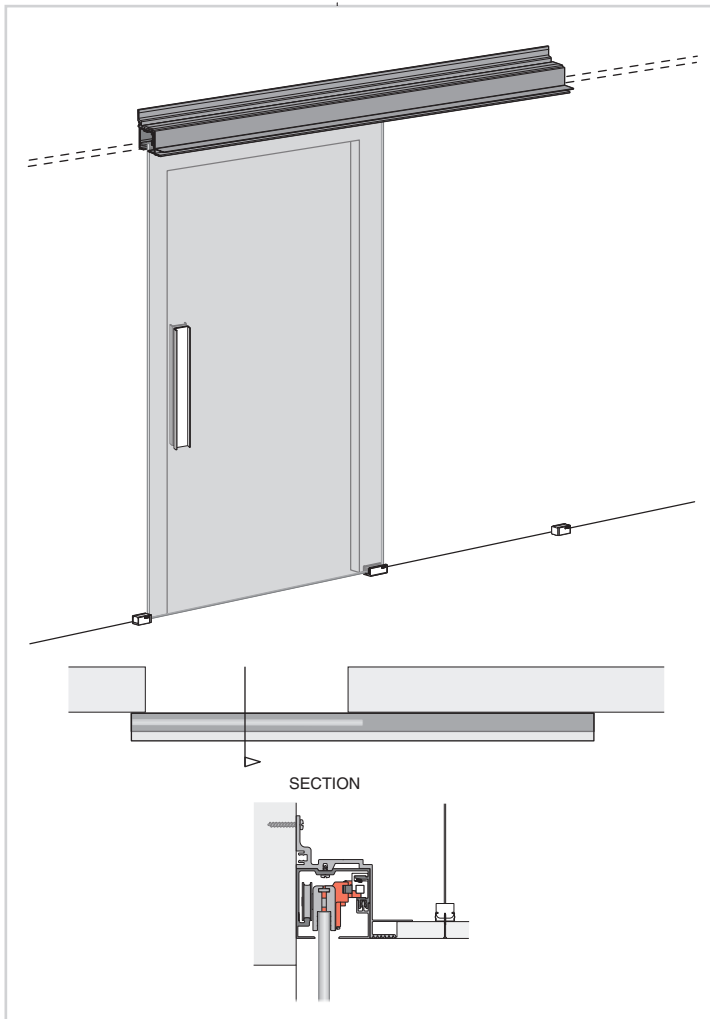

INSTALACIÓN EMPOTRADA SIN DINTEL
RECESSED INSTALLATION WITHOUT LINTEL

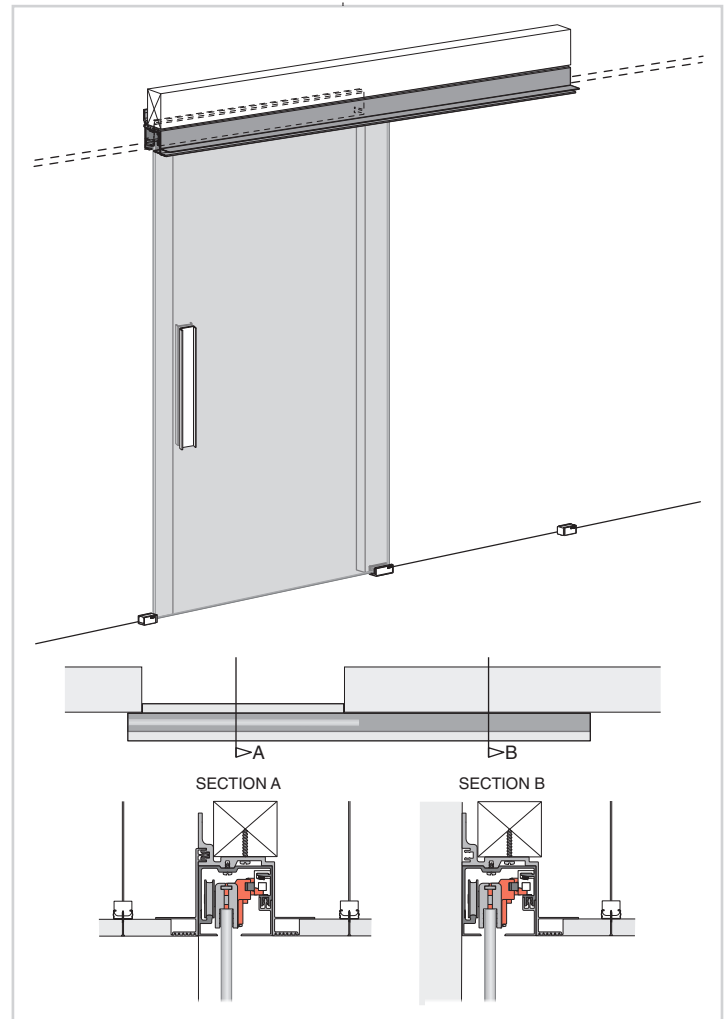

2 INFORMACIÓN DE SEGURIDAD / SAFETY INFORMATION

El vidrio de la puerta corredera debe cumplir con las normas:

- ASTM C1036-16 Standard Specification for Flat Glass
- ASTM C1048-12e1 Standard Specification for Heat-Strengthened and Fully Tempered Glass
- ASTM C1172-14 Standard Specification for Laminated Architectural Flat Glass

La tolerancia admitida para el vidrio de la puerta corredera en espesores de 1/2" es de 11.91mm a 12.70mm.

Sliding glass door must be in compliance with the following regulations:

- ASTM C1036-16 Standard Specification for Flat Glass
- ASTM C1048-12e1 Standard Specification for Heat-Strengthened and Fully Tempered Glass
- ASTM C1172-14 Standard Specification for Laminated Architectural Flat Glass

Acceptable 1/2" glass thickness range must be within 11.91mm and 12.70mm.

3 HERRAMIENTAS NECESARIAS / REQUIRED TOOLS

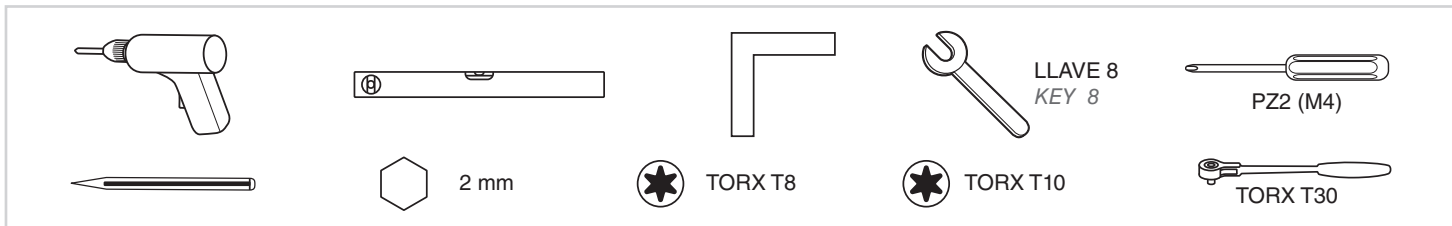

4 INFORMACIÓN GENERAL / GENERAL INFORMATION

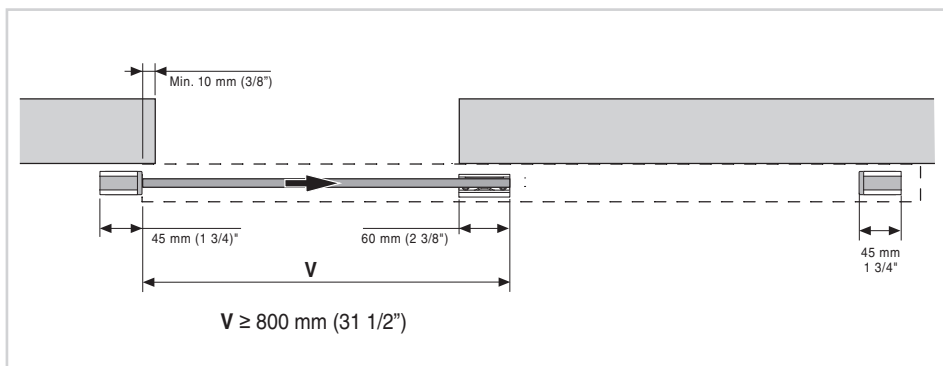
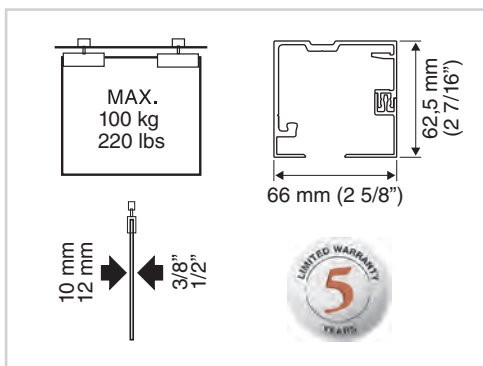

ALTURA DEL VIDRIO / GLASS HEIGHT

Aplicar la fórmula para determinar la altura del cristal según el tipo de instalación
Apply the formula to determine the glass height according to the type of installation

INSTALACIÓN VISTA / EXPOSED INSTALLATION

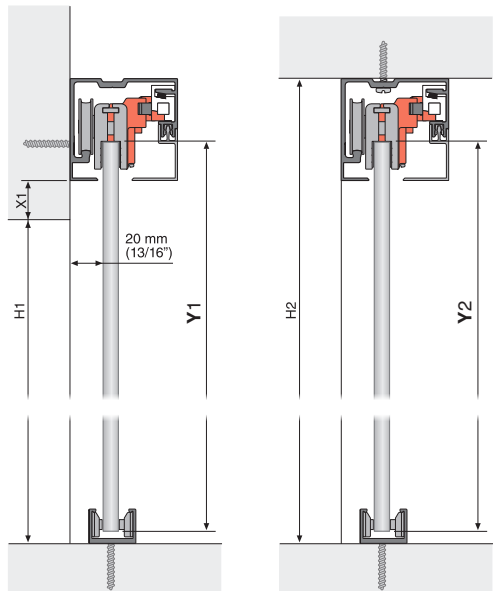

$$Y1 = H1 + X1 + 16 \text{ mm (5/8")}$$

$$Y2 = H2 - 47 \text{ mm (1 13/16")}$$

INSTALACIÓN EMPOTRADA / RECESSED INSTALLATION

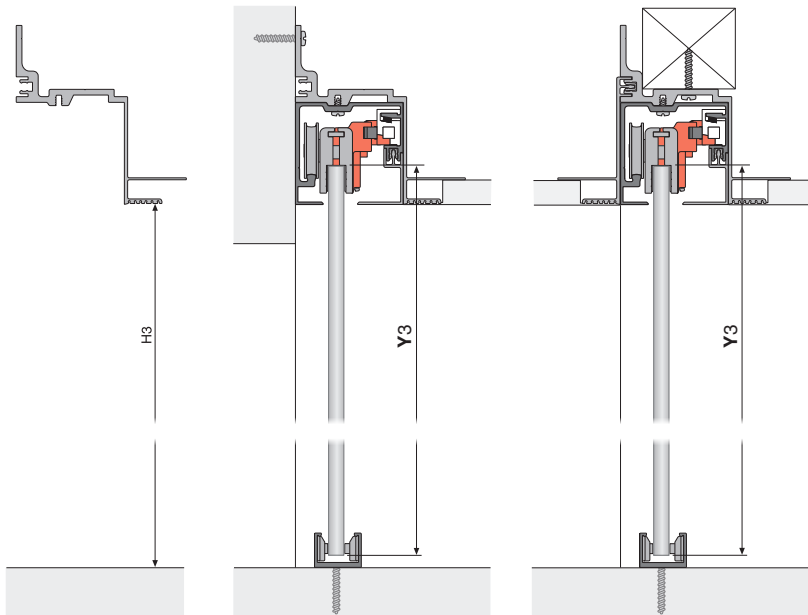

$$Y3 = H3 + 16 \text{ mm (5/8")}$$

6 MONTAJE DEL PERFIL PARA INSTALACIÓN VISTA UPPER TRACK MOUNTING FOR EXPOSED INSTALLATION

6.1 A PARED / WALL MOUNTED

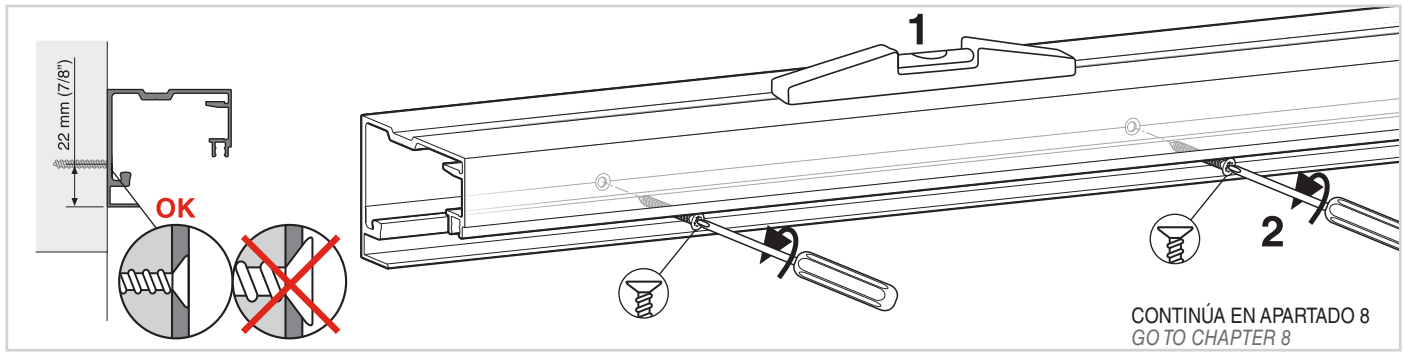

6.2 A TECHO / CEILING MOUNTED

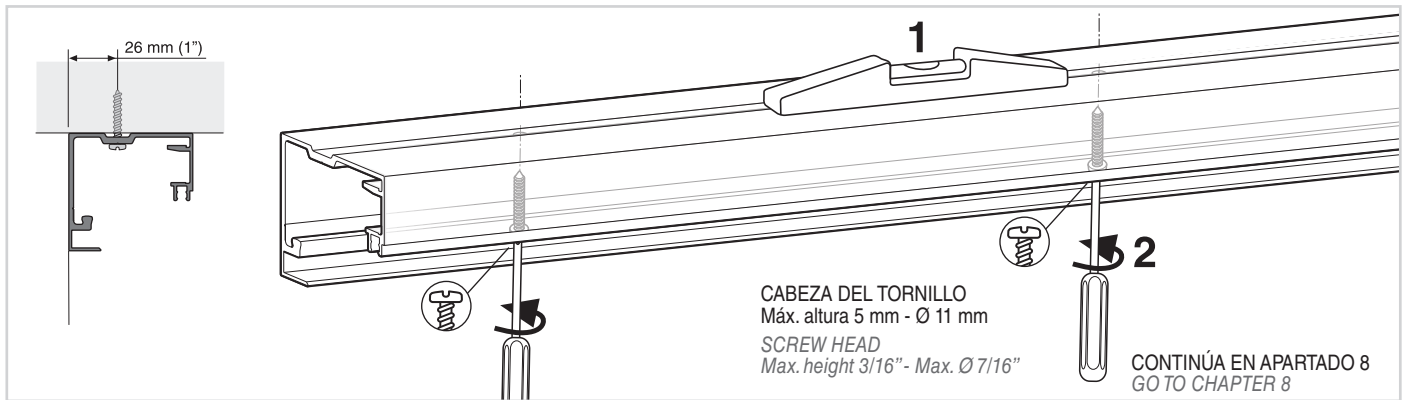

7 MONTAJE DEL PERFIL PARA INSTALACIÓN EMPOTRADA A FALSO TECHO UPPER TRACK MOUNTING FOR RECESSED INSTALLATION

FASE 1 - MONTAJE PERFIL MARCO STEP 1 - FRAME TRACK MOUNTING

7.1 CON DINTEL / WITH LINTEL

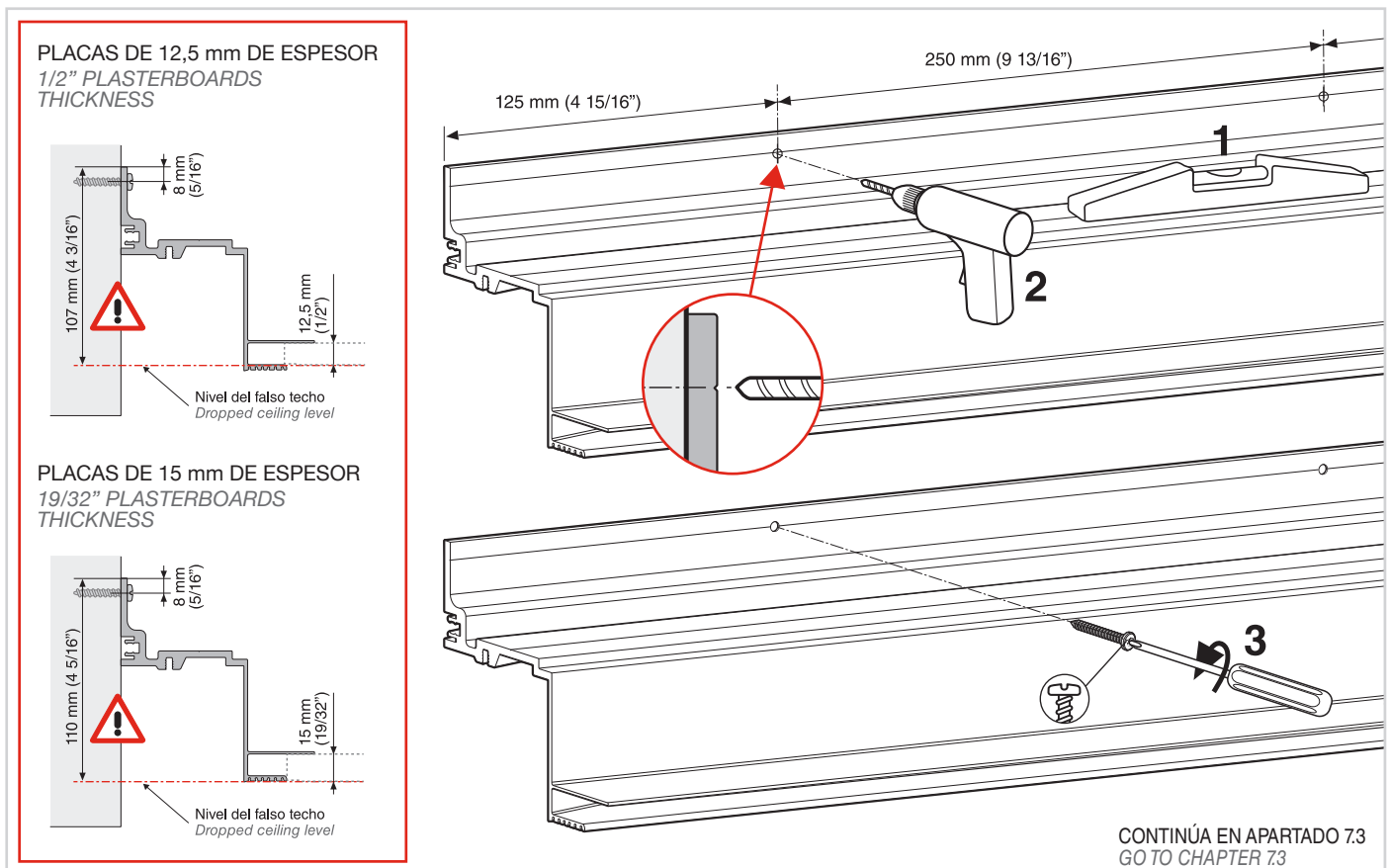

7.2 SIN DINTEL / WITHOUT LINTEL



PLACAS DE 12,5 mm DE ESPESOR
1/2" PLASTERBOARDS
THICKNESS

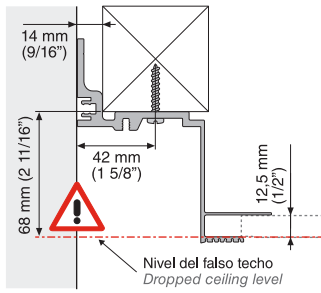

PLACAS DE 15 mm DE ESPESOR
19/32" PLASTERBOARDS
THICKNESS

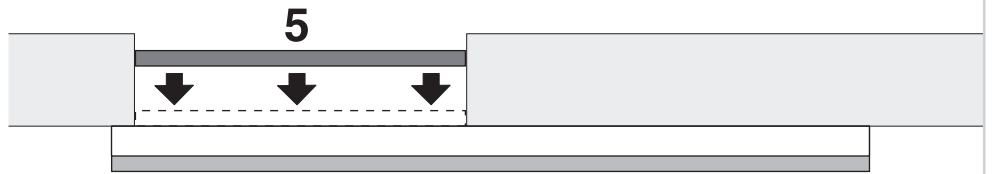
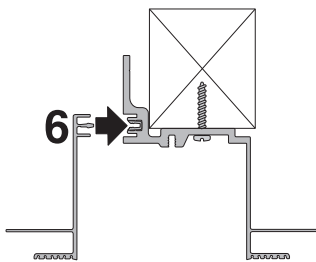
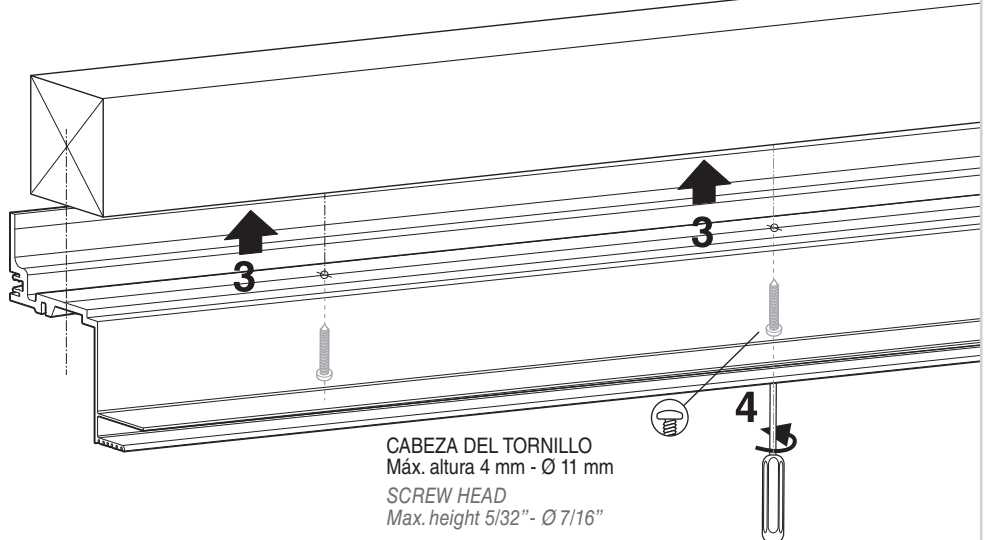
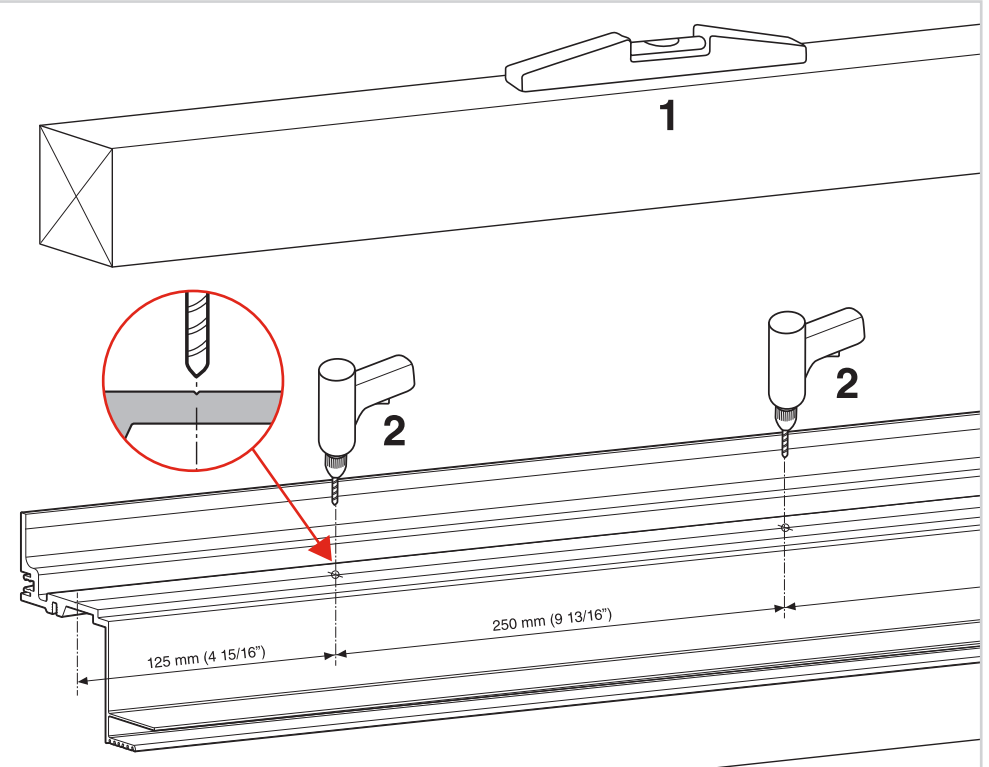
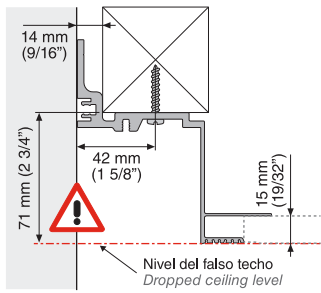

BOLSA / BAG 1

x20

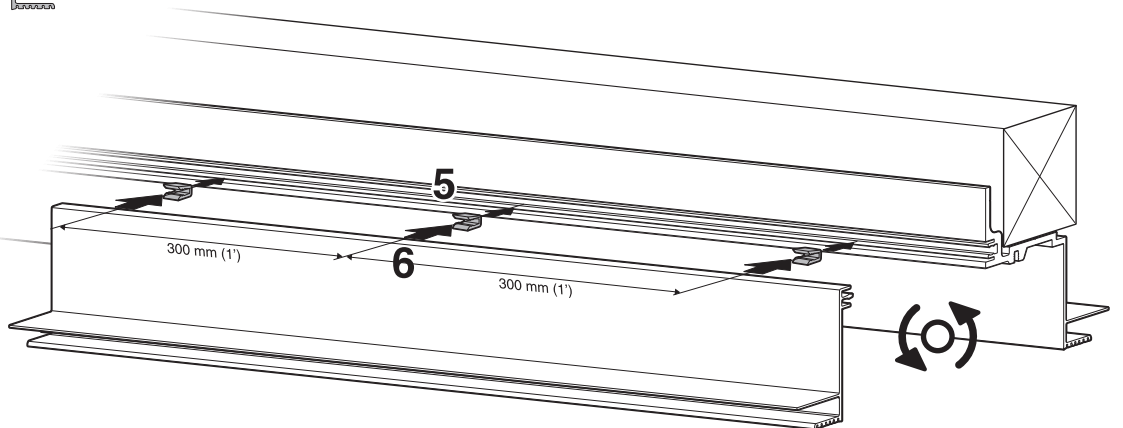

FASE 2 - ENCUENTRO A FALSO TECHO
STEP 2 - RECESSED CONNECTION

7.3 JUNTA ENTRE PERFIL MARCO Y PANEL
JOINT BETWEEN FRAME TRACK AND PLASTERBOARD



ESPEORES ADMITIDOS PARA PLACAS DE YESO LAMINADO
PERMITTED THICKNESSES FOR PLASTERBOARD

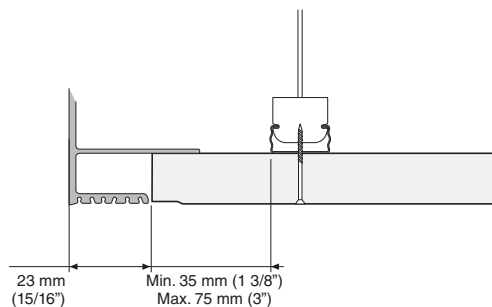
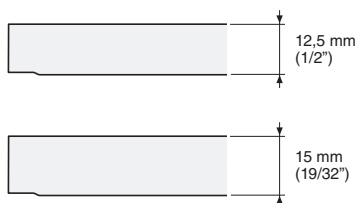

SEGUIR LAS INDICACIONES DEL FABRICANTE DE PLACAS DE YESO LAMINADO PARA LA JUNTA
FOLLOW THE INSTRUCTIONS OF THE PLASTERBOARD MANUFACTURER FOR THE JOINT

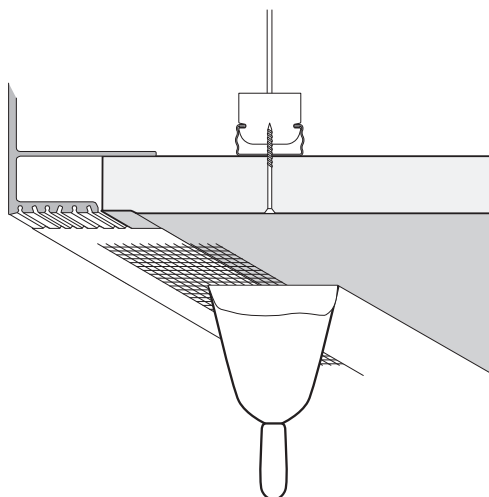

FASE 3 - MONTAJE PERFIL SUPERIOR
STEP 3 - UPPER TRACK MOUNTING

7.4 CON DINTEL / WITH LINTEL

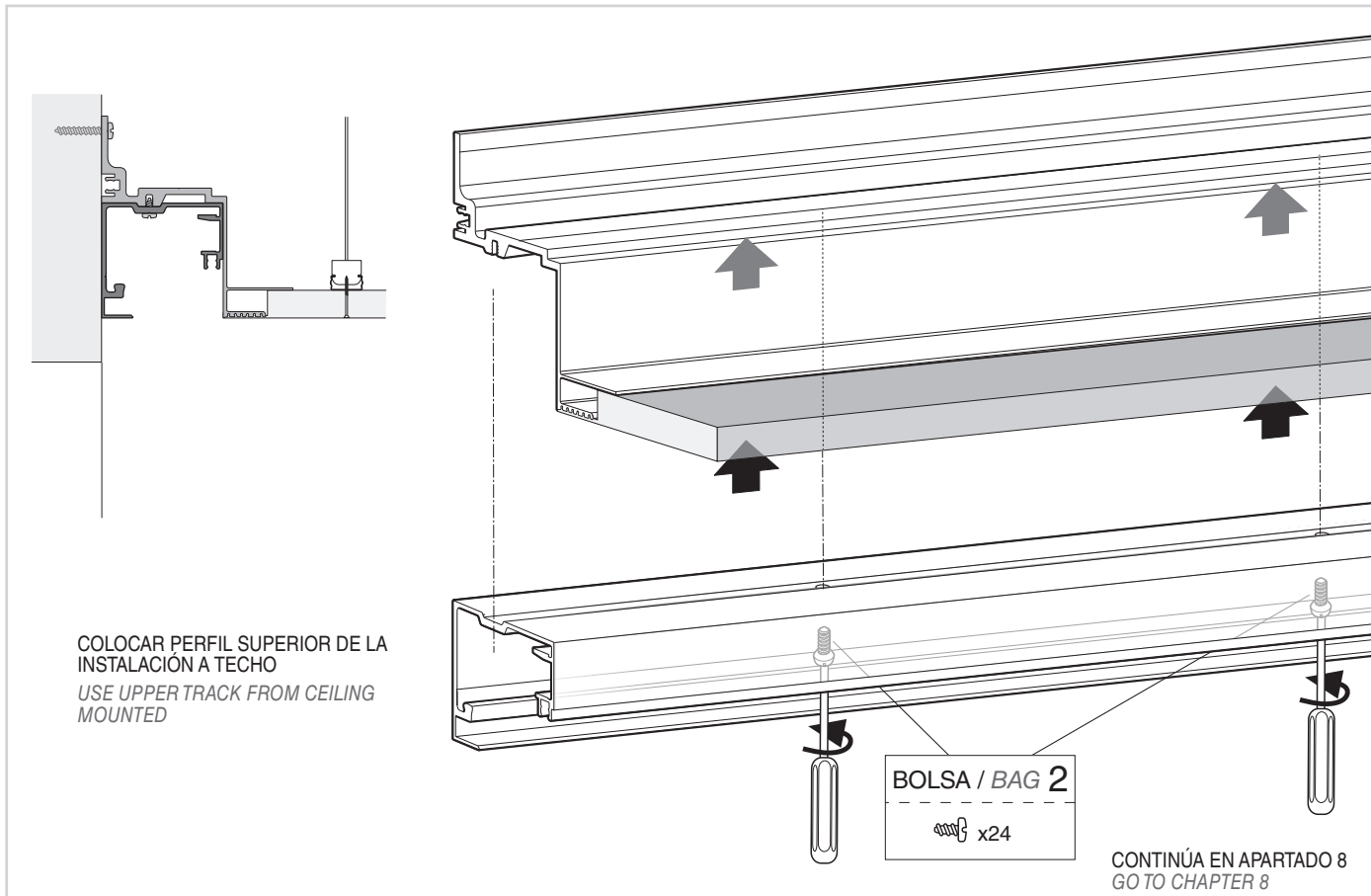

7.5 SIN DINTEL / WITHOUT LINTEL

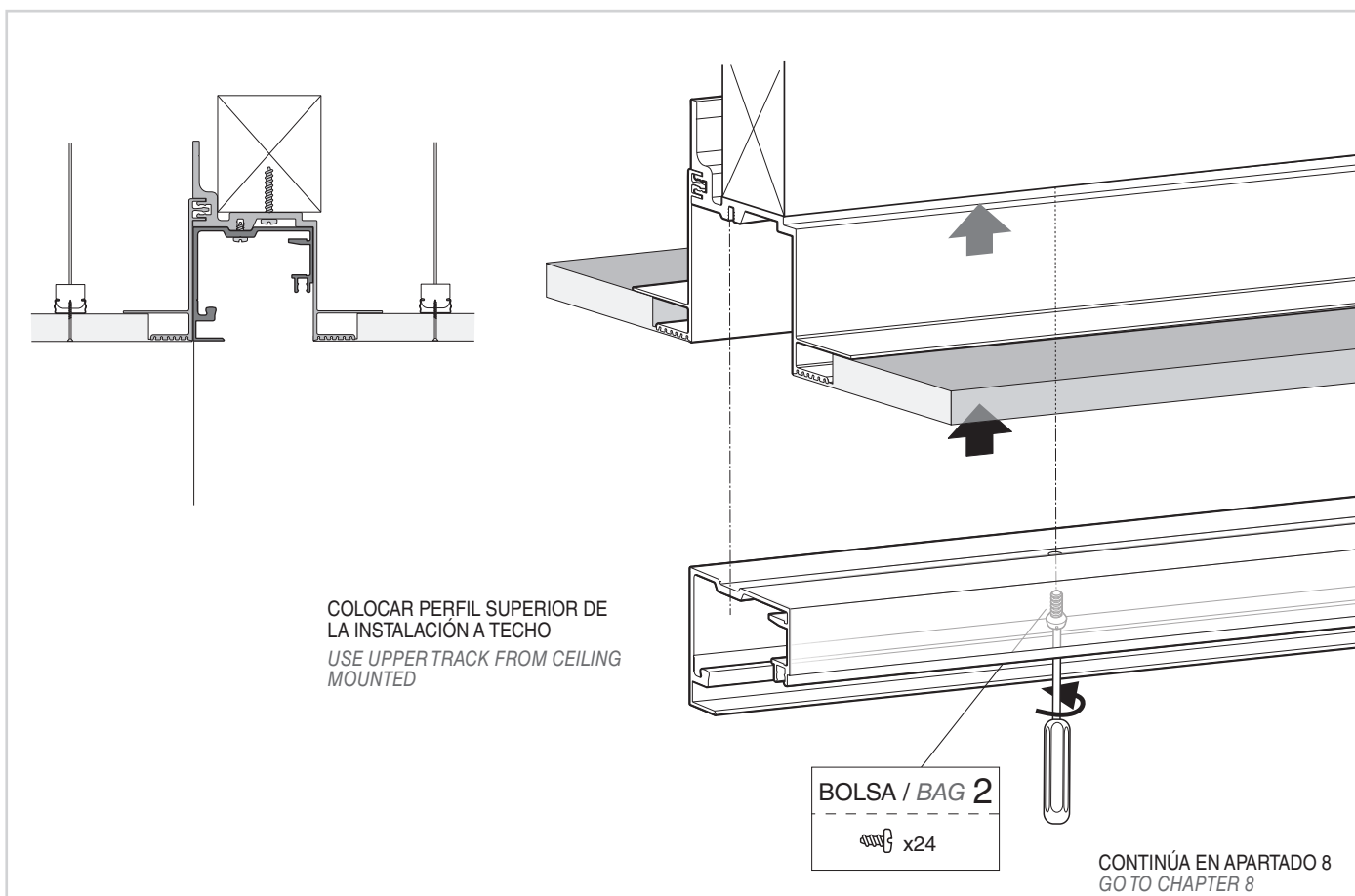

8 COLOCACIÓN DE MORDAZAS / CLAMP INSTALL

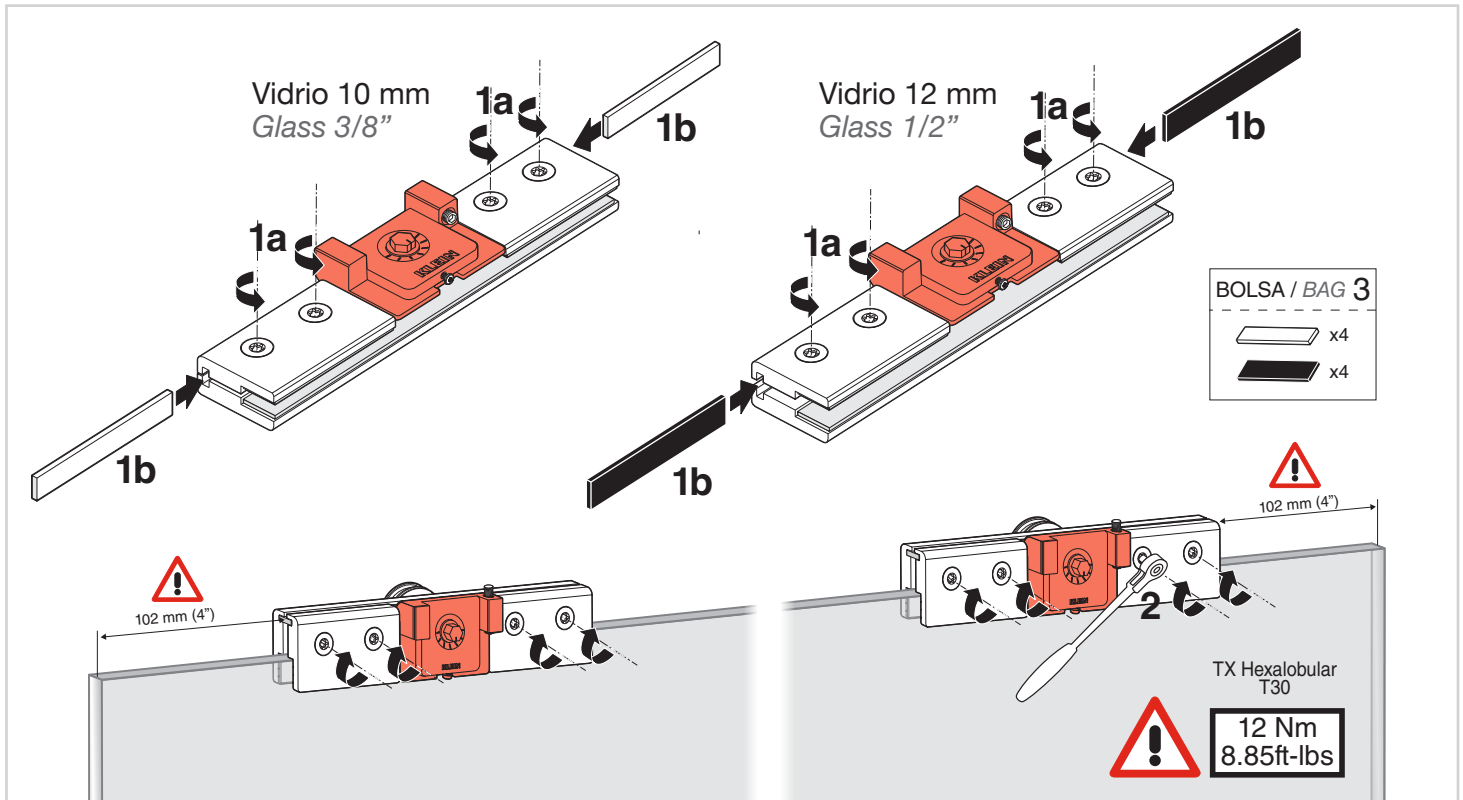

9 COLOCACIÓN DEL GUIADOR / GUIDE INSTALL

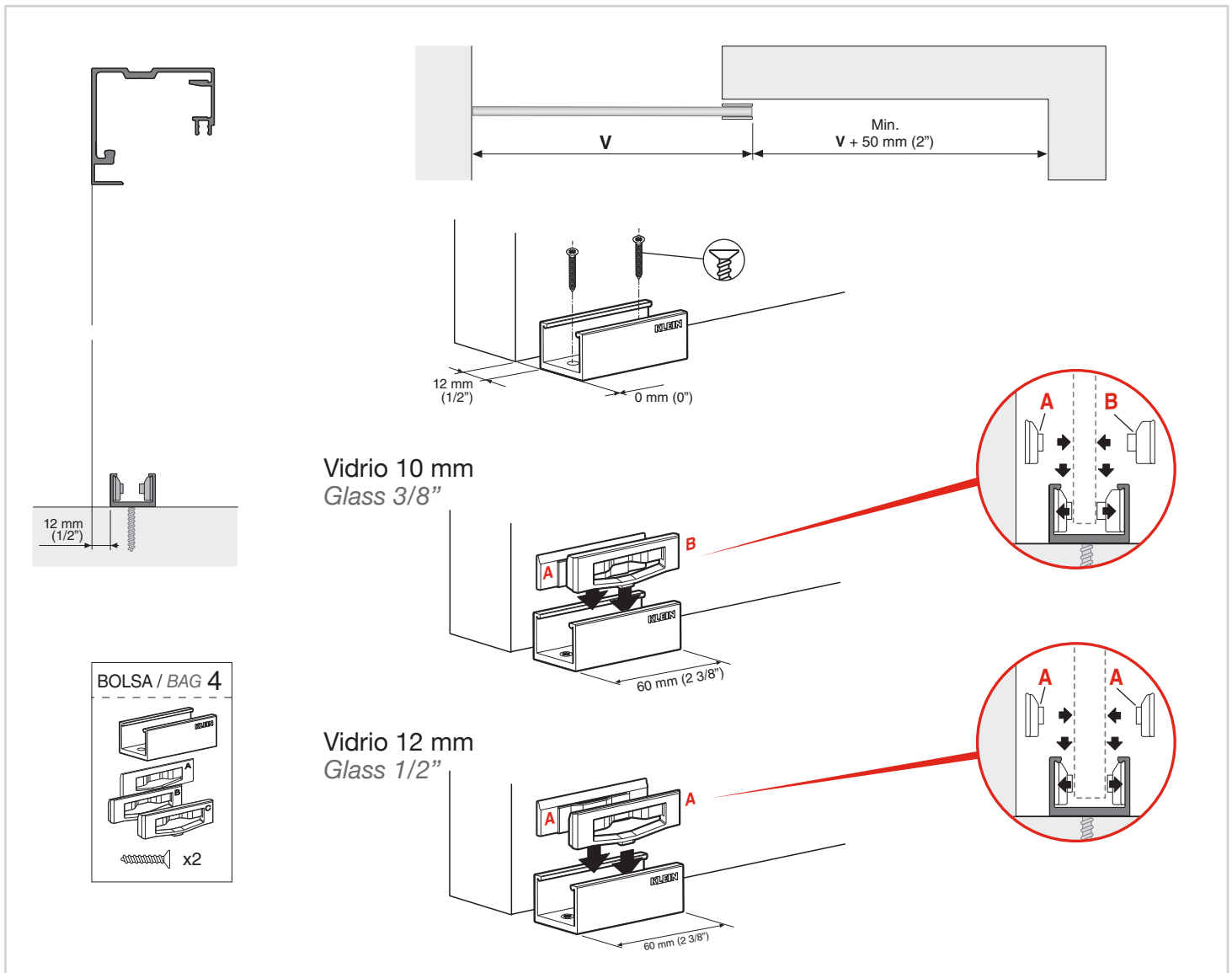

10 COLOCACIÓN DE LA PUERTA / DOOR MOUNTING

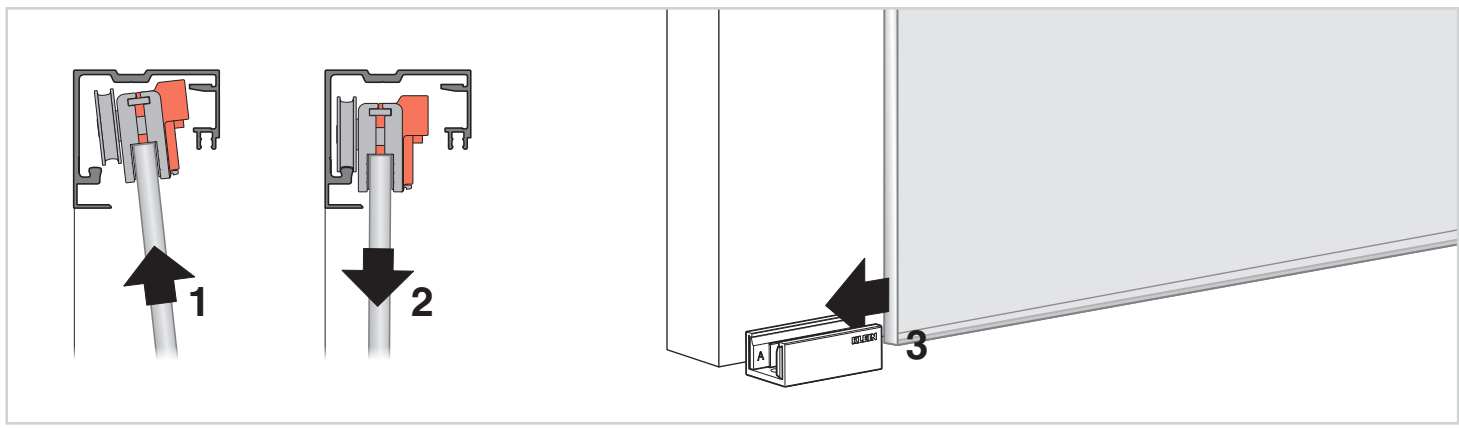

11 REGULACIÓN DE LA ALTURA / HEIGHT ADJUSTMENT

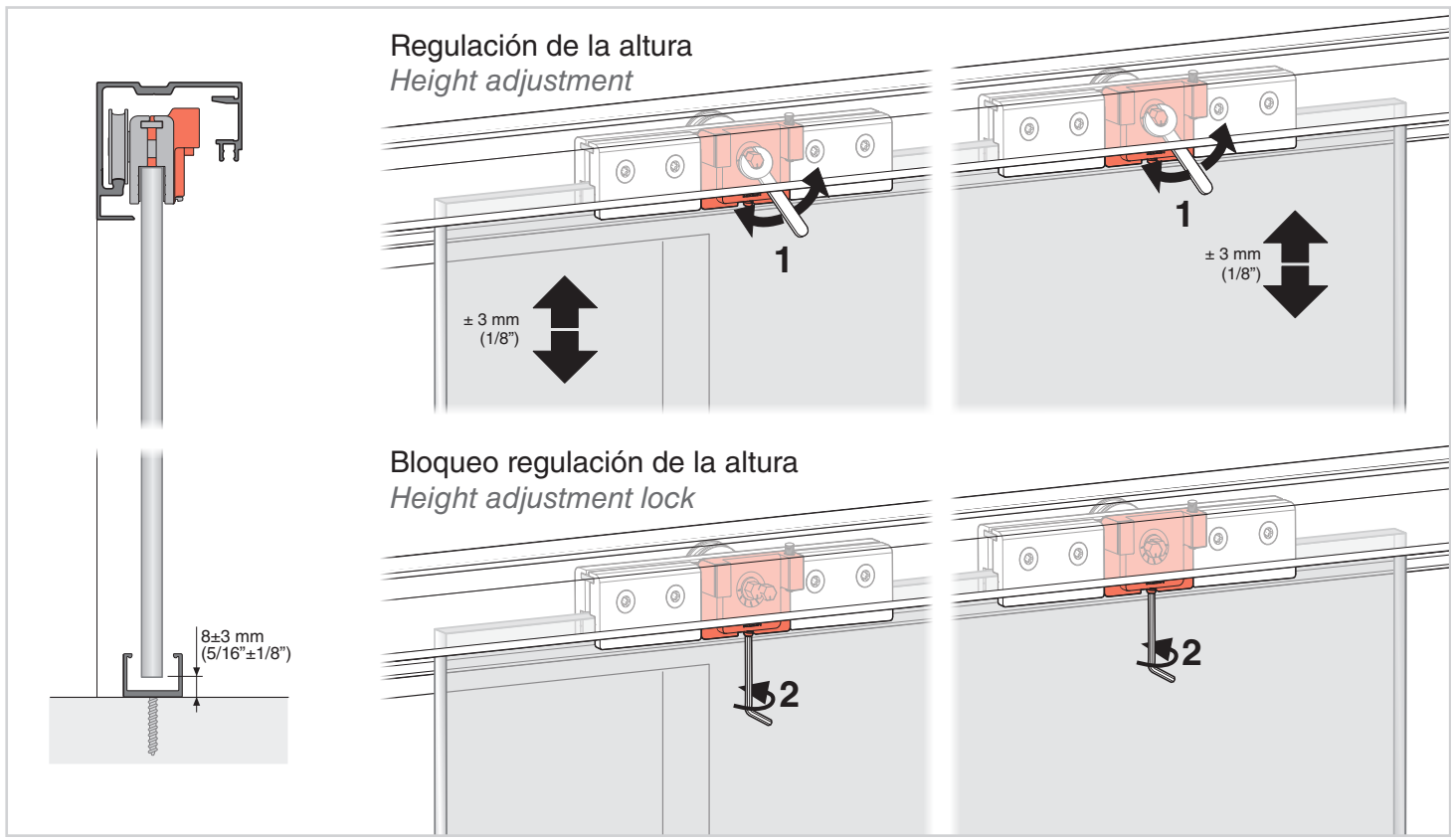

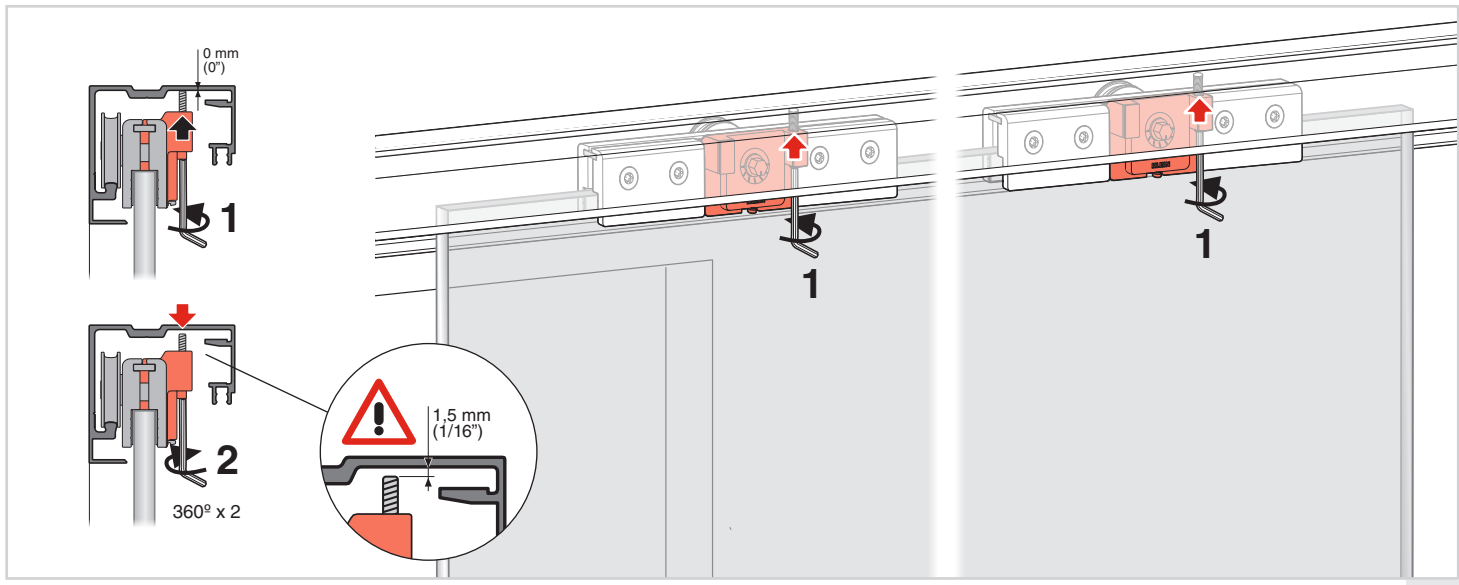

12 ANTIDESCABALGAMIENTO / ANTI-JUMP

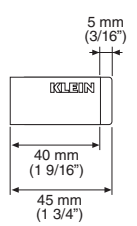
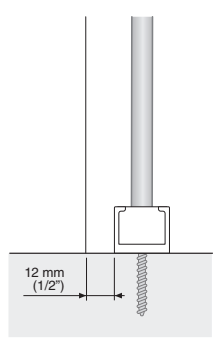

13 COLOCACIÓN DE LOS TOPES INFERIORES / BOTTOM STOPPER INSTALL

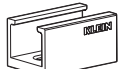
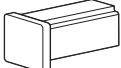

- BOLSA / BAG 6**
-  x2
 -  x2
 -  x4

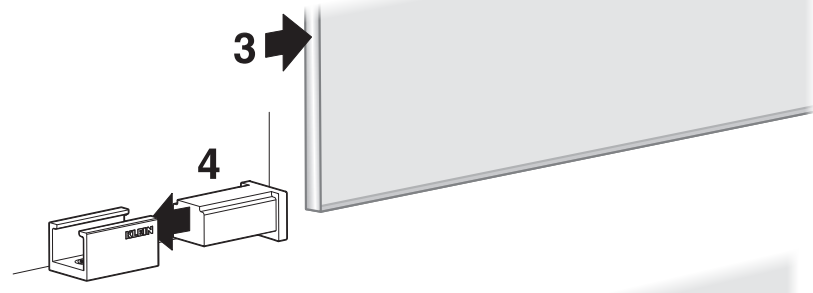
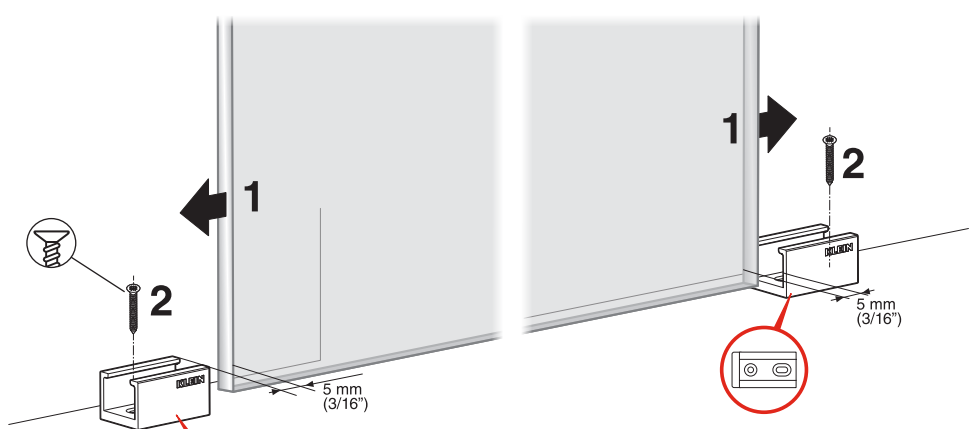

Ajuste final mediante el coliso
Final adjustment through the slotted hole

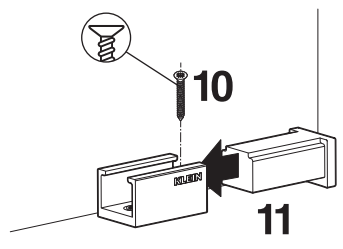
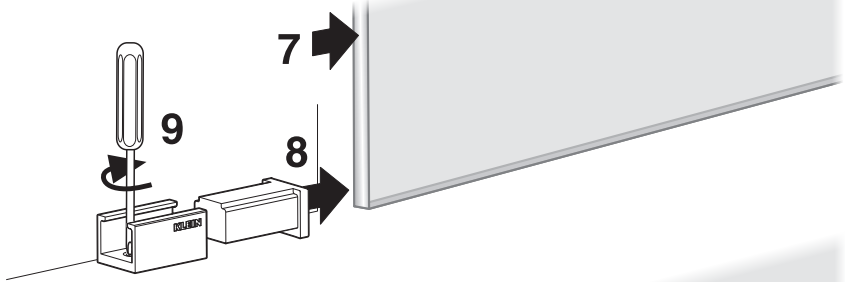
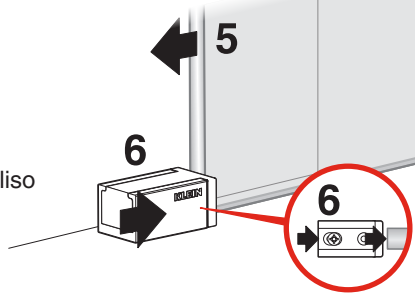

14 COLOCACIÓN DE LOS KSC / KSC INSTALL

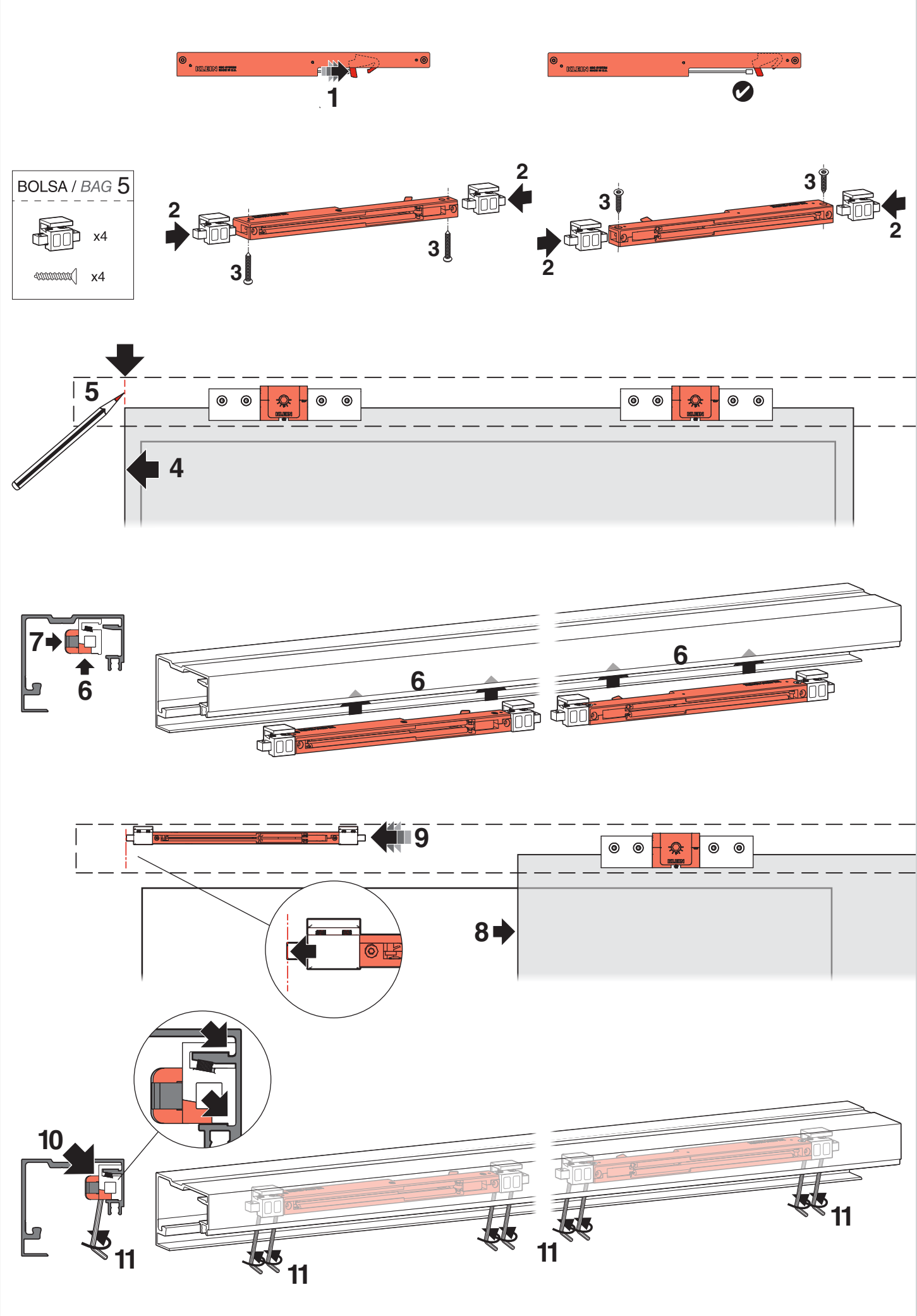

15 COLOCACIÓN DE LA GALERÍA / VALANCE INSTALL

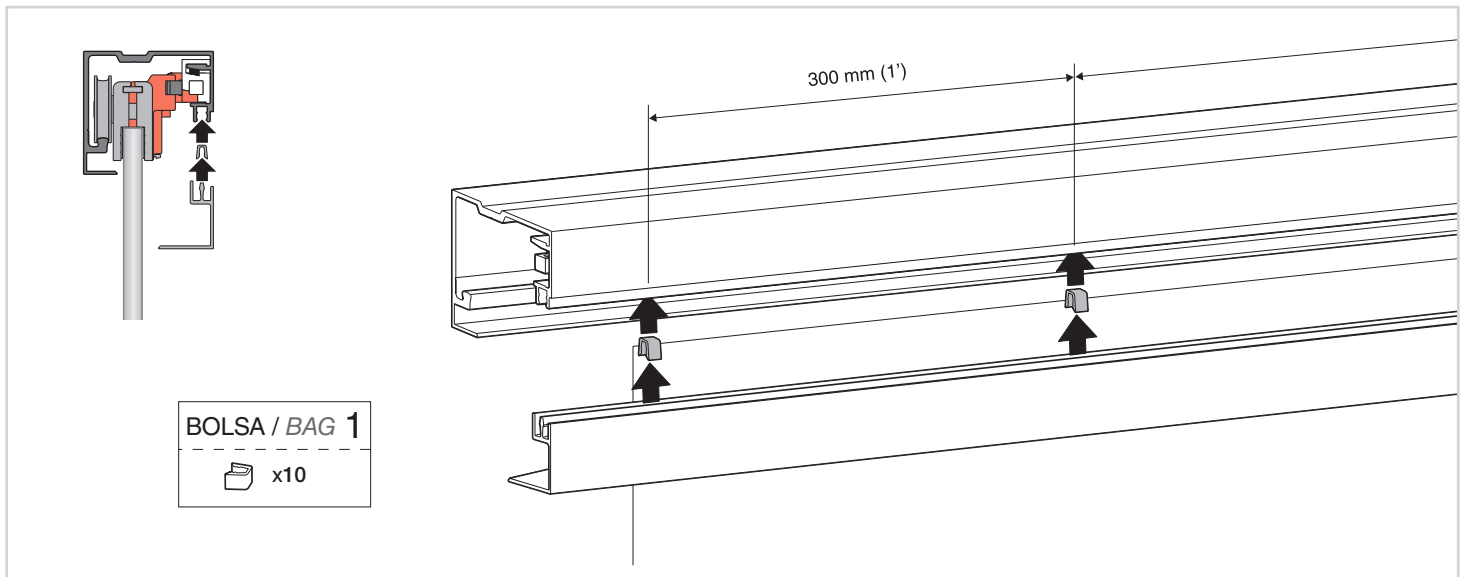

16 COLOCACIÓN DE LAS TAPAS LATERALES DEL PERFIL SUPERIOR END CAP INSTALL

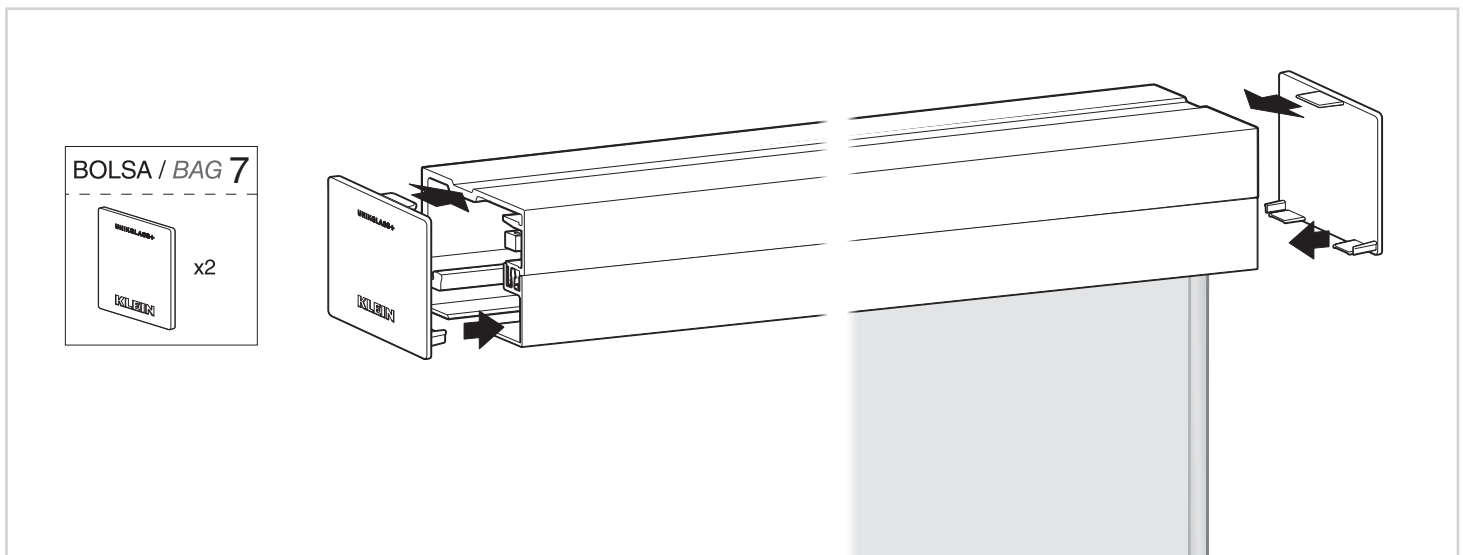

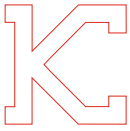

Limited Warranty.

- (1) KLEIN USA, Inc. warrants to the immediate customer only that the delivered goods are free of original material defects and defects in workmanship for a period of five years from date of receipt by the customer. All warranty claims are subject to inspection by KLEIN USA, Inc. prior to KLEIN USA, Inc. providing a remedy for the warranty claim.
- (2) Excluded from this warranty are products, or parts of them, subject to wear through use, and products which have not been used in accordance with their technical characteristics and for purposes for which they have not been designed, being understood that the products sold by KLEIN USA, Inc. are designed exclusively for the enclosure of spaces, with the enclosing running precisely in the longitudinal sense.
- (3) Also excluded from this warranty are those products in which the limits expressed in the product documentation have been exceeded for weights and dimension supported by the product, and/or recommendations for the qualities of the material to which the products sold by KLEIN USA, Inc. are fixed have not been complied with.
- (4) KLEIN USA, Inc. makes no warranty with respect to the following: a) materials not manufactured by KLEIN USA, Inc. or any other group companies, the use of which is suggested by KLEIN USA, Inc. or any other group companies general recommendations, application or installation procedures or otherwise; b) All display items sold by KLEIN USA, Inc. to the Customer
- (5) Warranties are exclusive, and in lieu of all other warranties, express or implied, written or oral, including but not limited to, any implied warranty of merchantability or fitness for any particular purpose. KLEIN USA, Inc. does not assume, nor authorize any representative or other person to assume for it, any obligation or liability other than as expressly set forth herein.
- (6) For the warranty to take effect, the defective product must be sent with the voucher or purchase invoice to the Company, which will then process to repair or replace the product, at its choice.
- (7) KLEIN USA, Inc. will accept no other responsibility than the repair or replacement of the product and only for the purchaser of the product, so the rights granted by this warranty may not be assigned to third parties.

Extent of liability.

- (1) In case of a breach of contractual obligations, defective deliveries, tortuous acts or producers liability, KLEIN USA, Inc. shall only be obliged to compensate damages or expenses –subject to any other contractual or statutory conditions for liability– if it acted intentionally or with gross negligence or in cases of minor negligence, if such negligence results in the breach of an essential contractual duty (a duty the breach of which puts the fulfillment of the purpose of the contract at risk). The liability of KLEIN USA, Inc. shall be limited to typical damages which are foreseeable at the time of the conclusion of the contract.
- (2) The liability of KLEIN USA, Inc. for losses caused by late delivery due to minor negligence shall be limited to 5% of the agreed purchase price.
- (3) The exclusions and limitations of liability in sections (1) – (2) shall not apply in cases where KLEIN USA, Inc. has maliciously failed to disclose a defect, in case of damages resulting from death, injury to health or physical injury where the laws on product liability impose overriding liabilities which cannot be excluded.
- (4) The limitation period for claims against KLEIN USA, Inc. –based on whatever legal ground- is 12 months from the date of delivery to the customer and in case of tortuous claims 12 months from the date the customer becomes aware or would have become aware of the grounds giving rise to a claim and the liable person had he not been grossly negligent. The provisions in this section (4) shall neither apply in cases of intentional or gross negligent breaches of duty nor shall they apply in cases referred to in section 13. (3).

Force Majeure.

- (1) KLEIN USA, Inc. shall not be liable for any default or delay in the production or delivery of all or any goods resulting either directly or indirectly from: a) Accidents to, breakdowns, or mechanical failure of KLEIN USA, Inc. or any other group companies' plant, machinery or equipment, strikes or other labour troubles, labour shortages, fire, flood, wars, acts of the public enemy, acts of God, delays of suppliers, delays in transportation or lack of transportation facilities, embargos, shortages or reductions of energy sources, priorities, allocations, limitations, restrictions or other acts required or requested by federal, state or local governments or any other bureau or agency thereof; b) Any action beyond the control of the Company.
- (2) In no event shall KLEIN USA, Inc. or any other group companies be liable for any consequential, special, or contingent damages arising out of KLEIN USA, Inc. or any other group companies default or delay in filling the customer's order.

Industrial Property Rights, Copyrights.

- (1) Industrial property rights and copyrights to any goods or material of KLEIN USA, Inc. shall remain exclusively the proprietary of the Company.
- (2) In the event of claims against the customer because of breach of an industrial property right or a copyright in using the Company's deliveries or services, KLEIN USA, Inc. shall be responsible to obtain the right for the customer to continue using such deliveries or services, provided that the customer gives immediate written notice of such third-party claims and KLEIN USA, Inc. rights to take all appropriate defensive and out-of-court actions are reserved. If, despite such actions, it proves impossible to continue using the Company's deliveries or services under reasonable economic conditions, it shall be understood as agreed that KLEIN USA, Inc. may, at its discretion, modify or replace the particular delivery or service for removal of a legal deficiency, or reship such delivery or service with refunding of the sales price previously paid to KLEIN USA, Inc. less a certain deduction to account for the age of the delivery or service in question.
- (2) The customer shall have no further claims alleging infringement of industrial property or copyrights, if KLEIN USA, Inc. has not either violated essential contractual duties or has intentionally or grossly negligently breached contractual duties. KLEIN USA, Inc. shall have no liability where breaches of rights are caused by exploiting Company's deliveries or services in any other way than quoted by KLEIN USA, Inc. or by operating these together with any other than Company's deliveries or services.

411-8404 09-17 PK-24

KLEIN®

KLEIN USA - 1 Madison Street, East Rutherford, NJ 07073
Phone: 973 246 81 81 - Fax: 973 246 83 62
Technical Support: technicalinfo@klein-usa.com - www.klein-usa.com

